

LFPG6100 (6V100Ah)

Specifications

Nominal Voltage		6 V
Capacity (25°C)	20HR(5.25V)	100 Ah
	5HR(5.10V)	78Ah
	1HR(4.80V)	58.2Ah
Dimension	Length	194 ± 2mm (7.64inch)
	Width	170 ± 2mm (6.69inch)
	Height	205 ± 2mm (8.07inch)
	Total Height	210 ± 2mm (8.27inch)
Approx. Weight		15.8kg (34.7lbs) ± 4%
Terminal type		T9
Internal resistance (Fully charged, 25°C)		Approx. 3.3m Ω
Capacity affected by temperature (10HR)	40°C	103%
	25°C	100%
	0°C	88%
	-15°C	70%
Self-discharge (25°C)	3 month	Remaining Capacity: 94%
	6 month	Remaining Capacity: 88%
	12 month	Remaining Capacity: 75%
Nominal operating temperature		25°C ± 3°C (77°F ± 5°F)
Operating temperature range	Discharge	-15°C ~ 55°C (5°F ~ 131°F)
	Charge	-10°C ~ 55°C (14°F ~ 131°F)
	Storage	-20°C ~ 55°C (-4°F ~ 131°F)
Float charging voltage(25°C)		6.76 to 6.90V Temperature compensation: -9mV/°C
Cyclic charging voltage(25°C)		7.05 to 7.20V Temperature compensation: -15mV/°C
Maximum charging current		20A
Terminal material		Copper
Maximum discharge current		1000A(5 sec.)
Designed floating life(20°C)		15 years

- ◆ Gelled electrolyte technology;
- ◆ PVC separator;
- ◆ Recognized by UL & CE;
- ◆ ABS container.

Constant Current Discharge Characteristics (A, 25°C)

F.V/TIME	15min	30min	60min	2h	3h	4h	5h	6h	8h	10h	20h	48h	120h
4.80V	135	93.2	58.2	34.0	24.0	18.9	15.8	13.5	10.5	9.37	5.11	---	---
4.95V	132	91.3	57.3	33.8	23.8	18.8	15.7	13.4	10.4	9.35	5.10	----	---
5.10V	127	88.5	55.9	33.5	23.7	18.6	15.6	13.3	10.4	9.32	5.06	2.23	---
5.25V	123	86.4	54.8	33.0	23.5	18.5	15.5	13.2	10.3	9.26	5.00	2.22	0.92
5.40V	116	83.2	53.1	32.2	22.8	17.9	15.0	12.8	9.99	9.20	5.00	2.22	0.92

Constant Power Discharge Characteristics (Watt, 25°C)

F.V/TIME	15min	30min	60min	2h	3h	4h	5h	6h	8h	10h	20h	48h	120h
4.80V	754	531	335	198	142	112	94.0	80.0	62.5	56.0	30.8	---	---
4.95V	735	521	330	197	141	111	93.5	79.5	62.5	56.0	30.8	---	----
5.10V	708	505	322	195	140	110	92.5	79.0	62.0	56.0	30.7	13.4	----
5.25V	684	493	316	192	139	110	92.0	78.5	61.5	55.5	30.2	13.3	5.55
5.40V	648	475	306	187	135	106	89.5	76.0	59.5	55.0	30.3	13.3	5.50

Note: The above characteristics data can be obtained within three charge/discharge cycles.

Dimensions

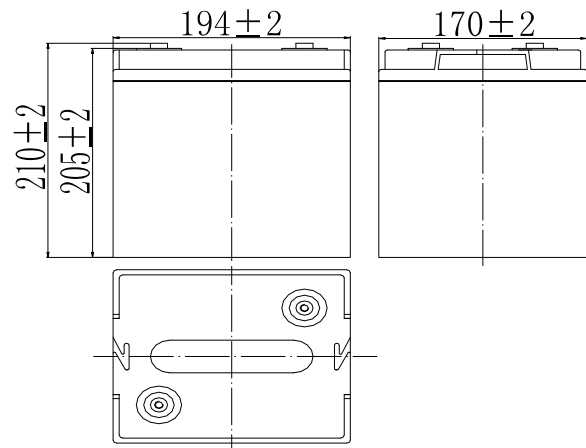

Terminal

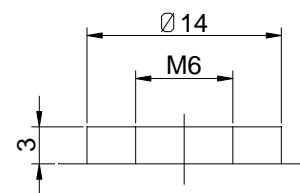

Terminal T9

LFPG6100 (6V100Ah)

Discharge Characteristics(25°C)

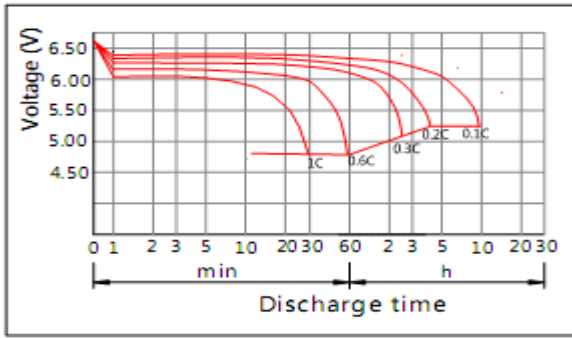

Charging Characteristics(25°C)

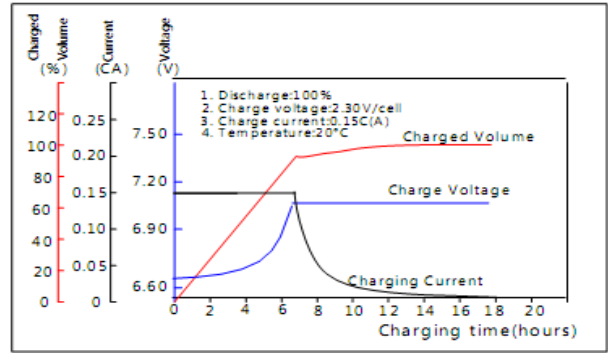

Effect of Temperature on Capacity

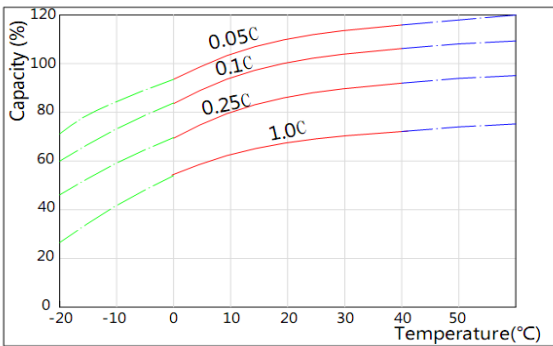

Self-discharge Characteristics

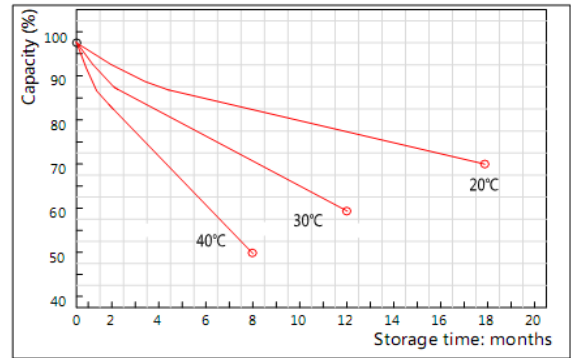

The Relationship for Open Circuit Voltage and Residual Capacity (25°C)

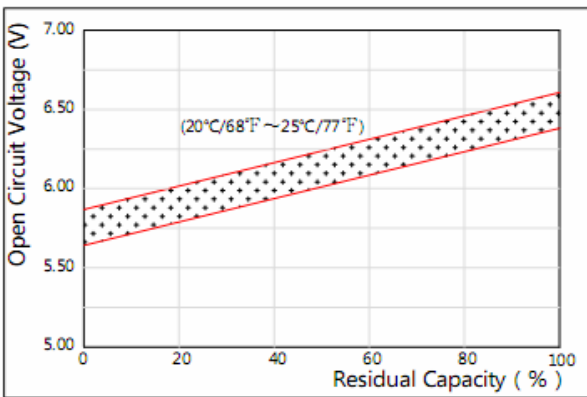

The Relationship for Charging Voltage and Temperature

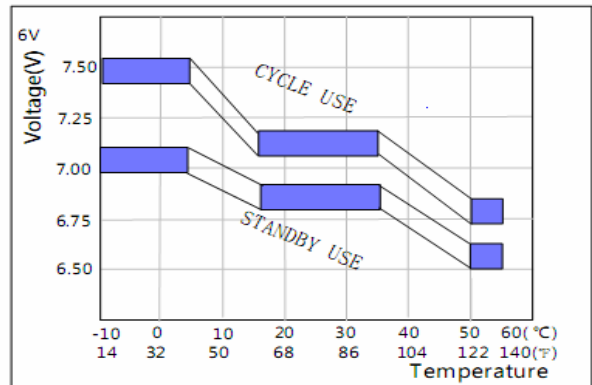

Floating Life on Temperature

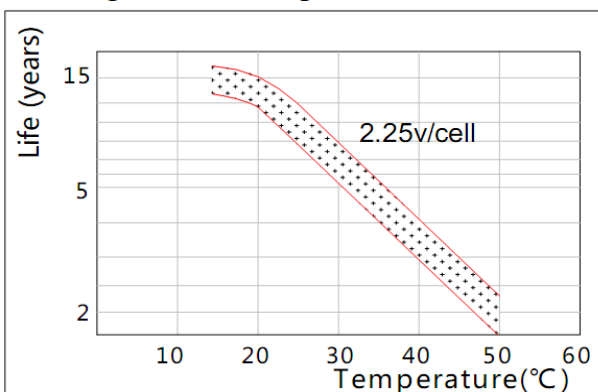

Cycle Life on D.O.D(25°C)

