

LFP12150FTT (12V150Ah)

Specifications

Nominal Voltage		12 V
Capacity (25°C)	10HR(10.8V)	165Ah
	5HR(10.8V)	145Ah
	1HR(9.60V)	102Ah
Dimension	Length	546 ± 3mm (21.50inch)
	Width	125 ± 2mm (4.92inch)
	Height	317 ± 2mm (12.48inch)
	Total Height	323 ± 2mm (12.72inch)
Approx. Weight		50kg (110.2lbs) ± 4%
Terminal type		T11
Internal resistance (Fully charged, 25°C)		Approx. 4mΩ
Capacity affected by temperature (10HR)	40°C	102%
	25°C	100%
	0°C	85%
	-15°C	65%
Self-discharge (25°C)	3 month	Remaining Capacity: 91%
	6 month	Remaining Capacity: 82%
	12 month	Remaining Capacity: 65%
Nominal operating temperature		25°C ± 3°C (77°F ± 5°F)
Operating temperature range	Discharge	-15°C ~ 50°C (5°F ~ 122°F)
	Charge	-10°C ~ 50°C (14°F ~ 122°F)
	Storage	-20°C ~ 50°C (-4°F ~ 122°F)
Float charging voltage(25°C)		13.50 to 13.80V Temperature compensation: -18mV/°C
Cyclic charging voltage(25°C)		14.50 to 14.90V Temperature compensation: -30mV/°C
Maximum charging current		45A
Terminal material		Copper
Maximum discharge current		1100A(5 sec.)
Designed floating life(20°C)		15 years

- ◆ Absorbent glass mat technology;
- ◆ Recognized by UL & CE;
- ◆ ABS container.

Constant Current Discharge Characteristics (A, 25°C)

F.V/TIME	15min	30min	60min	2h	3h	4h	5h	6h	8h	10h	20h
9.60V	272	165	102	60.3	42.1	34.5	30.0	25.7	20.2	16.8	8.75
9.90V	266	162	101	59.9	41.8	34.3	29.8	25.6	20.1	16.8	8.71
10.2V	256	157	98.2	59.4	41.5	34.1	29.5	25.4	19.9	16.7	8.68
10.5V	247	153	96.3	58.5	41.3	33.8	29.3	25.2	19.8	16.6	8.62
10.8V	234	147	93.3	57.0	40.0	32.8	29.0	24.5	19.2	16.5	8.50

Constant Power Discharge Characteristics (Watt, 25°C)

F.V/TIME	15min	30min	60min	2h	3h	4h	5h	6h	8h	10h	20h
9.60V	3742	2989	1851	1166	698	495	406	348	304	240	201
9.90V	3630	2918	1814	1149	694	492	403	346	303	239	200
10.2V	3480	2810	1759	1120	688	488	401	344	300	237	200
10.5V	3331	2714	1716	1097	678	485	398	341	298	235	198
10.8V	3143	2571	1653	1064	660	471	386	331	289	228	197

Note: The above characteristics data can be obtained within three charge/discharge cycles.

Dimensions

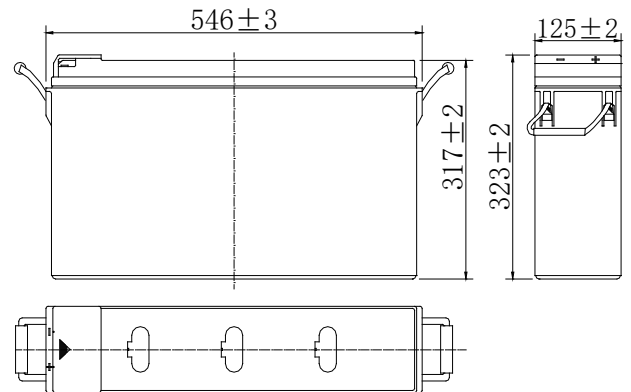

Terminal

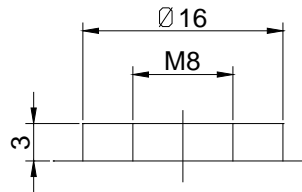

Terminal T11

LFP12150FTT (12V150Ah)

Discharge Characteristics(25°C)

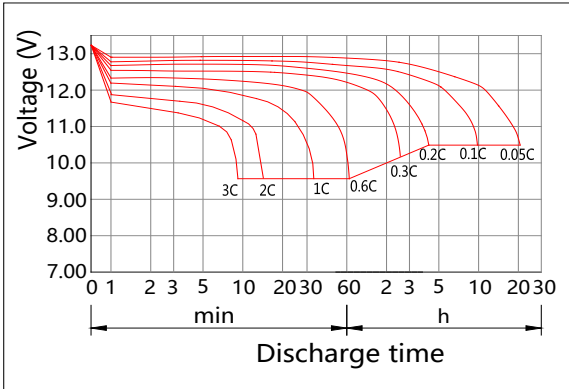

Charging Characteristics(25°C)

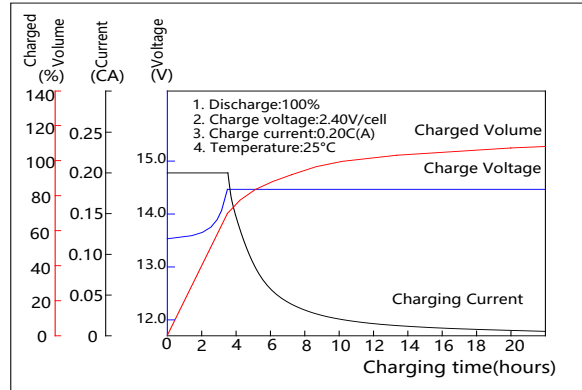

Effect of Temperature on Capacity

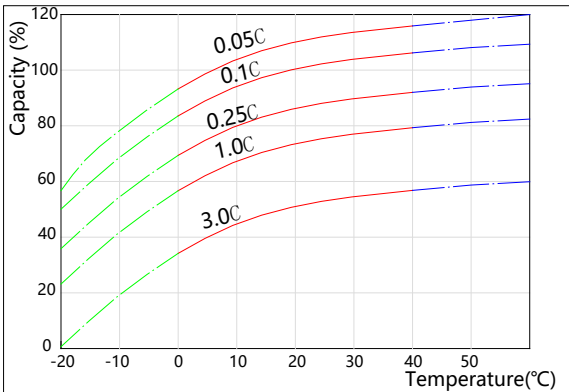

Self-discharge Characteristics

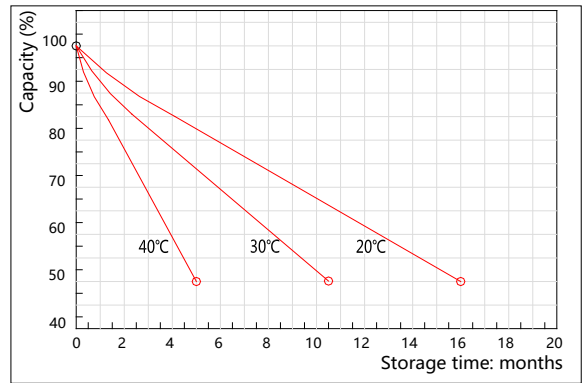

The Relationship for Open Circuit Voltage and Residual Capacity (25°C)

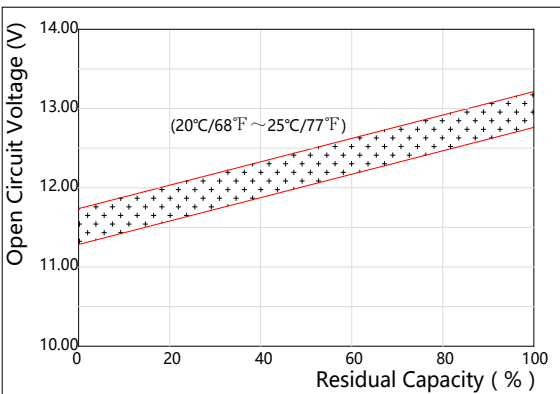

The Relationship for Charging Voltage and Temperature

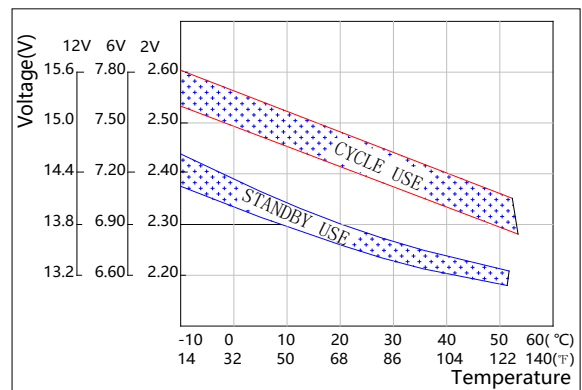

Floating Life on Temperature

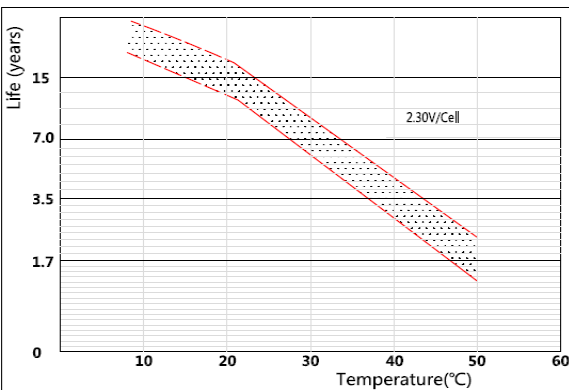

Cycle Life on D.O.D(25°C)

