

LFP12180KFT(12V180Ah)

Specifications

Nominal Voltage		12 V
Capacity (25°C)	10HR(10.8V)	180 Ah
	5HR(10.5V)	157Ah
	1HR(9.60V)	112Ah
Dimension	Length	560 ± 3mm (22.05inch)
	Width	126 ± 2mm (4.96inch)
	Height	280 ± 2mm (11.02inch)
	Total Height	280 ± 2mm (11.02inch)
Approx. Weight		53kg (116.9lbs) ± 4%
Internal resistance (Fully charged, 25°C)		Approx. 3.6m Ω
Capacity affected by temperature (10HR)	40°C	102%
	25°C	100%
	0°C	85%
	-15°C	65%
Self-discharge (25°C)	3 month	Remaining Capacity: 91%
	6 month	Remaining Capacity: 82%
	12 month	Remaining Capacity: 65%
Nominal operating temperature		25°C ± 3°C (77°F ± 5°F)
Operating temperature range	Discharge	-15°C ~ 50°C (5°F ~ 122°F)
	Charge	-10°C ~ 50°C (14°F ~ 122°F)
	Storage	-20°C ~ 50°C (-4°F ~ 122°F)
Float charging voltage(25°C)		13.50 to 13.80V Temperature compensation: -18mV/°C
Cyclic charging voltage(25°C)		14.50 to 14.90V Temperature compensation: -30mV/°C
Maximum charging current		54A
Terminal material		Copper
Maximum discharge current		1300A(5 sec.)
Designed floating life(20°C)		15 years

- ◆ Absorbent glass mat technology;
- ◆ Recognized by UL & CE;
- ◆ ABS container.

Constant Current Discharge Characteristics (A, 25°C)

F.V/TIME	15min	30min	60min	2h	3h	4h	5h	6h	8h	10h	20h
9.60V	291	176	112	65.8	45.9	37.6	32.1	28.1	22.0	18.3	9.62
9.90V	284	173	110	65.4	45.6	37.4	31.9	27.9	21.9	18.3	9.60
10.2V	274	168	107	64.8	45.3	37.2	31.7	27.7	21.8	18.2	9.57
10.5V	264	164	105	63.8	45.0	36.9	31.5	27.5	21.6	18.1	9.52
10.8V	250	158	102	62.2	43.7	35.8	30.6	26.7	21.0	18.0	9.45

Constant Power Discharge Characteristics (Watt, 25°C)

F.V/TIME	15min	30min	60min	2h	3h	4h	5h	6h	8h	10h	20h
9.60V	3196	1979	1272	762	540	443	380	332	262	219	115
9.90V	3119	1940	1253	757	537	440	378	330	260	218	115
10.2V	3004	1880	1221	750	533	437	375	328	258	218	115
10.5V	2902	1835	1197	739	529	434	372	326	257	216	114
10.8V	2748	1767	1160	720	513	421	361	316	249	215	113

Note: The above characteristics data can be obtained within three charge/discharge cycles.

Dimensions

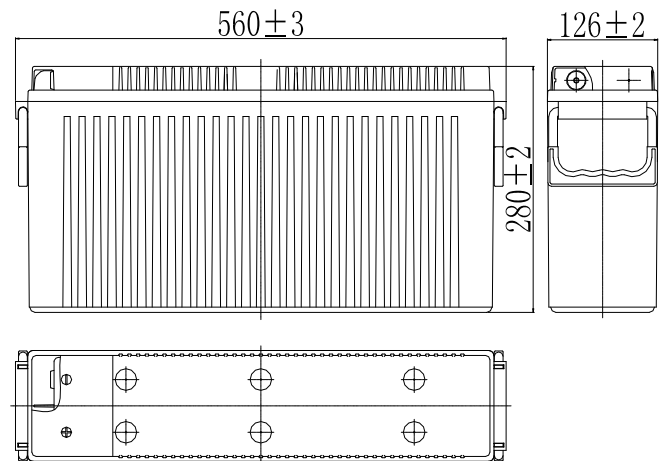

Terminal

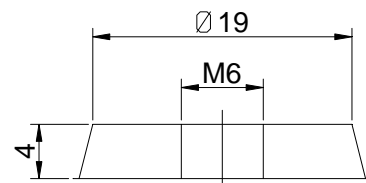

LFP12180KFT(12V180Ah)

Discharge Characteristics(25°C)

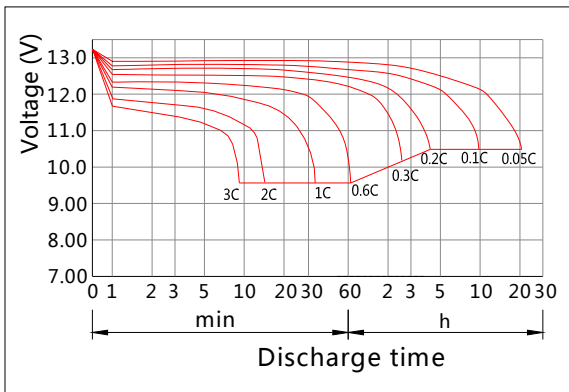

Charging Characteristics(25°C)

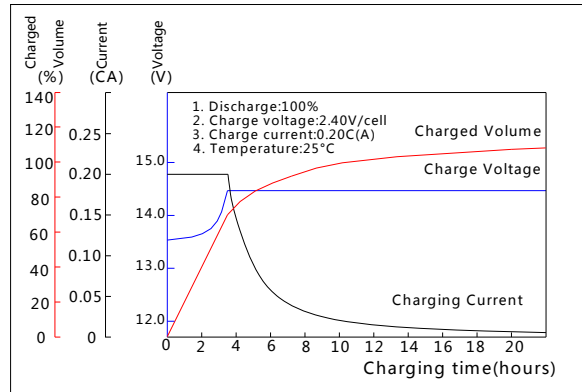

Effect of Temperature on Capacity

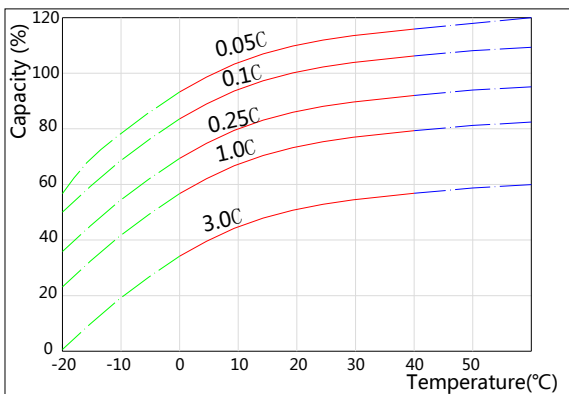

Self-discharge Characteristics

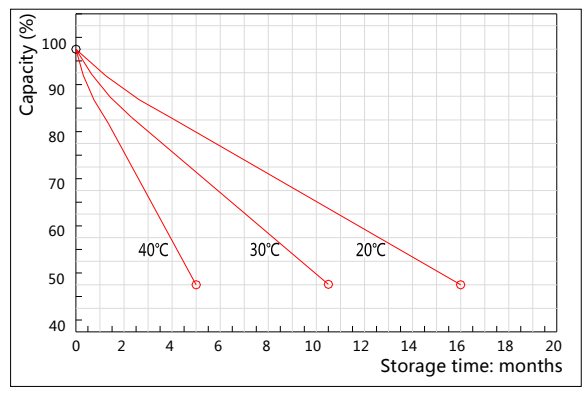

The Relationship for Open Circuit Voltage and Residual Capacity (25°C)

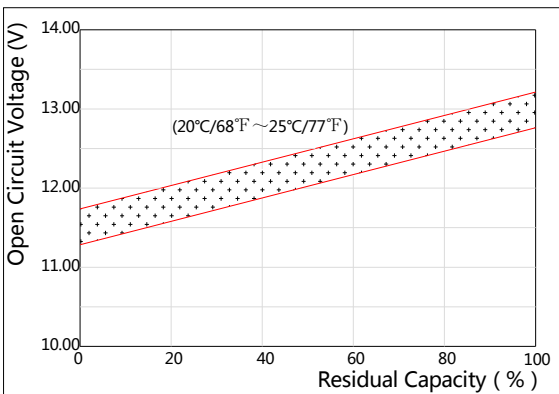

The Relationship for Charging Voltage and Temperature

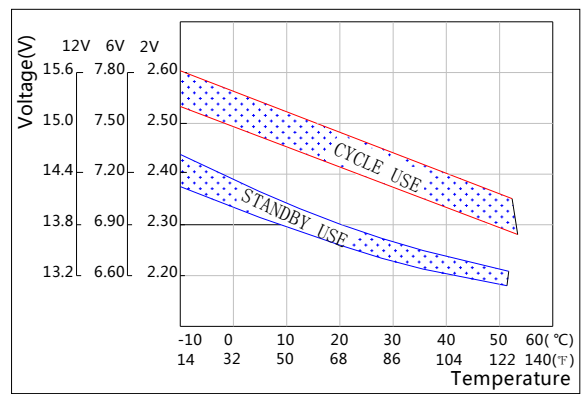

Floating Life on Temperature

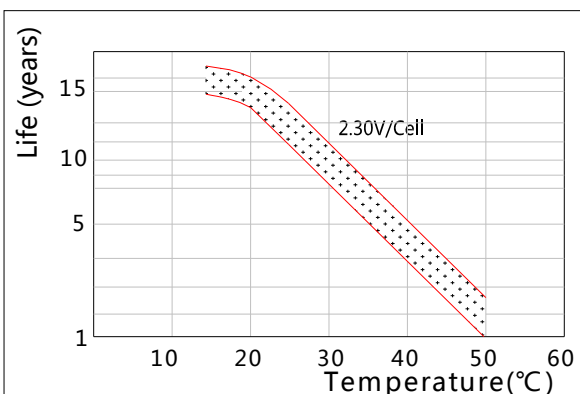

Cycle Life on D.O.D(25°C)

